Distributed Universal Constructions a guided tour

Michel RAYNAL

Institut Universitaire de France

Academia Europaea

IRISA, Université de Rennes, France

Polytechnic University (PolyU), Hong Kong

Content

- Short historical perspective and a point of view
- From sequential computing to distributed computing
- Distributed universal constructions
- Conclusion

Never forget

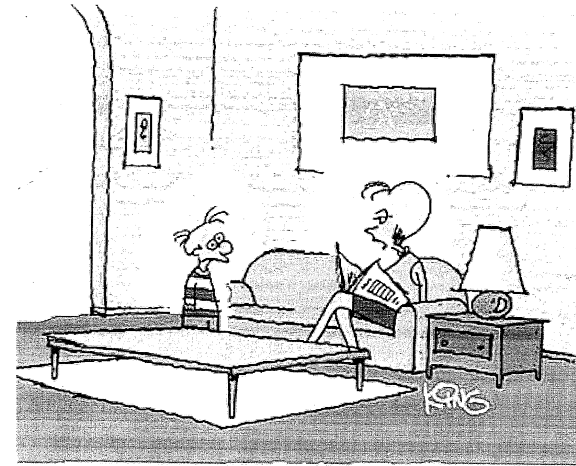

"No, you weren't downloaded.
You were born."

PART 1

Historical perspective
and ...
a point of view on what is
INFORMATICS

From the very beginning (?)
mankind is
Looking for UNIVERSALITY!

One upon a time...



Plimpton tablet 322

(1800 BC)

15 lines

Pythagorean triplets

$$(a^2 + b^2 = c^2)$$

Base sexagesimal base

Algorithms seem to be born with writing...
(only receipts at this time, no formalization, no proofs)

a few historical references

- Neugebauer O. E.,
The exact sciences in Antiquity
Princeton University Press (1952); 2nd edition: Brown University Press (1957), Reprint: Dover publications (1969)
- Kramer S. N.,
History begins at Sumer: thirty-nine firsts in man's recorded history
University of Pennsylvania Press, 416 pages (1956)
- Donald Knuth
Ancient Babylonian Algorithms
Communications of the ACM, 15(7):671-677 (1972)

A little bit later...



A great step ahead!

Axioms: **Euclid** (\simeq 300 BC)

"Ruler + compass" constructions

"Ruler + compass" define the set of allowed operations

We have: algorithms + proofs

Example: Bisecting an angle with compass + ruler

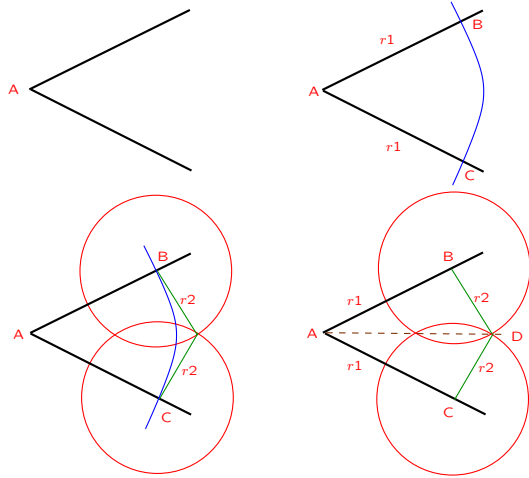

Proof: consists in showing that the triangles ABD and ACD are equal

BTW: what about trisecting an angle?

- Is it possible to **trisect an angle with a compass + ruler**?
- One of the hardest pb for Ancient Greeks (squaring the circle)
- Answer : impossibility proved in 1837 by Wantzel P. L.:
Recherches sur les moyens de reconnaître si un problème de géométrie peut se résoudre avec la règle et le compas, *Journal de mathématiques pures et appliquées*, 1(2):366-372 (1837)
- Plus the fact that π is a transcendent number (F. von Lindemann 1882)
- Hence **ruler+ compass operations are not universal** for geometric constructions!

Still a little bit later...



M. Ibn Musa Al Khawarizmi
780, Khiva - 850, Bagdad

Contributed to algebra ...
but gave its name to algorithms!

A few references



- Kitabu al-mukhtasar fi hisabi al-jabr wa'l-muqabala

- Kitabu al-jami' wa 't-tafriq bi-hisabi 'l-Hind
(the book of addition and subtraction from Indian calculus)

Closer to us



1912-1954

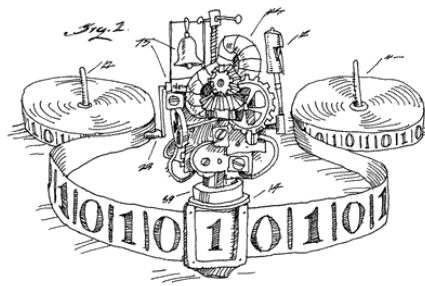

1936

- Turing A. M., On computable numbers with an application to the Entscheidungsproblem. *Proc. of the London Mathematical Society*, 42:230-265 (1936)

Two great colleagues!



1903-1995



1897-1954

ALGORITHMICS

The science of operations

Loking for universality!

- Founding result:
 - ★ $FSA \subset \text{Pushdown Automata} \subset \text{Turing Machines}$
 - ★ Machines to process SYMBOLS
- Church-Turing Thesis: universal machines
- Universality of data representation :
séquences de bits (books, images, files, etc.)

A very nice book by Harel D. and Feldman Y.: [Algorithmics: the spirit of computing](#).
3rd edition Springer, 572 pages (2012) [First edition: 1992]

A unifying view

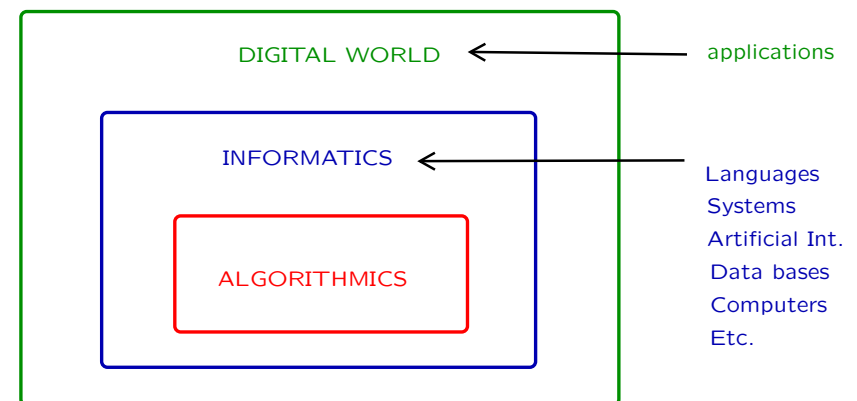

About informatics (1)

- Main resources:
 - ★ up to mid of XX-th century: matter/energy
 - ★ from mid of XX-th century: information
 - ★ as matter/energy: information can be collected, consumed, transformed, stored, carried, etc.
 - ★ differently from matter/energy: it does not burn, it can be copied at “zero cost”
- Looking for universality (just repeating...)

About informatics (2)

- Produces a “new” way of thinking (algorithmics-based)
- From **putting the world into equations**
to **putting the world into algorithms**
- **Informatics is the language of science!**

PART 2

From sequential computing
to distributed computing

The basic unit of sequential computing

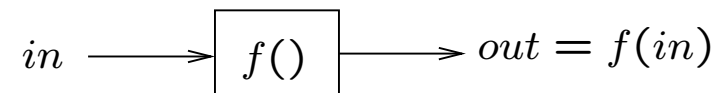

- The notion of a function
- Sequential algorithm
- The notion of computability (Turing machine)
- The notion of impossibility (e.g., halting problem)
- The fundamental hierarchy
FSA \subset Pushdown Automata \subset Turing Machines
- Church-Turing's Thesis

The case of parallel computing

- We look **inside the box implementing $f()$**
 - ★ mono-processor
 - ★ multiprocessor : to be more efficient
- The problem could be solved by a sequential algorithm, but can be solved more efficiently with several computing entities
- **Parallel computing is an “extension” of sequential computing looking for efficiency**
- This has a long story and introduced new techniques and concepts (e.g., task graphs, scheduling, etc.)

What is distributed computing?

DC arises when one has to solve a problem in terms of entities (processes, agents, sensors, peers, actors, nodes, processors, ...) such that **each entity has only a partial knowledge of the many parameters involved in the problem** that has to be solved

DC is about Mastering UNCERTAINTY

The basic unit of distributed computing

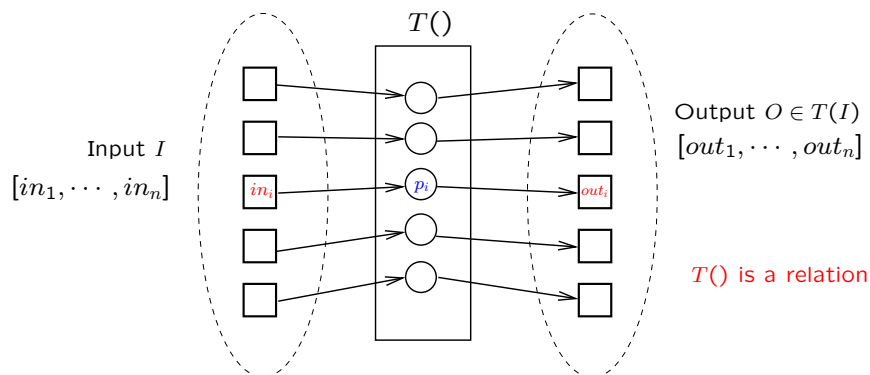

- The **notion of a task**: from an input vector to an output
- The **inputs are DISTRIBUTED** (this is **not under the control of the algorithm designer**)
- Failures belong to the model (in nearly all cases)

The notion of a (distributed) task

- A task T is a triple $(\mathcal{I}, \mathcal{O}, \Delta)$
 - ★ \mathcal{I} : set of input vectors (of size n)
 - ★ \mathcal{O} : set of output vectors (of size n)
 - ★ Δ : relation from \mathcal{I} into \mathcal{O} : $\forall I \in \mathcal{I} : \Delta(I) \subseteq \mathcal{O}$
- $I[i]$: private input of p_i
- $O[i]$: private output of p_i
- $\forall I \in \mathcal{I}$: $\Delta(I)$ defines the set of legal output vectors that can be decided from the input vector I

Examples of tasks

- Binary consensus
 - ★ $\mathcal{I} = \{\text{all vectors of 0 and 1}\}$
 - ★ $\mathcal{O} = \{\{0, \dots, 0\}, \{1, \dots, 1\}\}$
 - ★ Let $X_0 = \{0, \dots, 0\}$ and $X_1 = \{1, \dots, 1\}$
 - * $\Delta(X_0) = \{0, \dots, 0\}$ and $\Delta(X_1) = \{1, \dots, 1\}$
 - * $\Delta(\text{any vector except } X_0, X_1) = \mathcal{O}$
- k -set agreement, Renaming, Weak symmetry breaking
- k -Simultaneous consensus, etc.

Solving a task

A **distributed algorithm** A is a set of n local automata (Turing machines) that cooperate through specific communication objects (e.g., message-passing network, shared memory, etc.)

An **algorithm** A solves a **task** T if in any run

- $\exists I \in \mathcal{I}$ such that each p_i starts with (proposes) $in_i = I[i]$
- $\exists O \in \Delta(I)$ such that $O[j] = out_j$ for each process p_j that that computes (decides) an output out_j

Distributed computing: birth certificates

- L. Lamport, [Time, clocks, and the ordering of events in a distributed system](#). *Communications of the ACM*, 21(7):558-565 (1978)
 - ★ Partial order on events
 - ★ Scalar clocks
 - ★ State machine replication
- Fischer M.J., Lynch N.A., and Paterson M.S., [Impossibility of distributed consensus with one faulty process](#). *Journal of the ACM*, 32(2):374-382 (1985)
 - ★ Impossibility result in asynch. crash-prone systems
 - ★ Notion of valence (captures non-determinism)

A famous quote ... and its formalization

- “A distributed system is one in which the failure of a computer you didn’t even know existed can render your own computer unusable” (L. Lamport)
- Fischer M.J., Lynch N.A., and Paterson M.S., [Impossibility of distributed consensus with one faulty process](#). *Journal of the ACM*, 32(2):374-382 (1985)

Reminder: **DC is about Mastering UNCERTAINTY!**

To summarize

- **Real-time**: masters **On-time computing**
- **Parallelism**: provides **Efficiency**
- **Distributed computing**:

masters **Uncertainty**

(We are -more or less- implicitly using a lot of heuristics!)

Fundamental issue:
cope with the non-determinism created by the environment (asynchrony, failures)

PART 3

Universal constructions in crash-prone shared memory systems

Content

- Concurrent objects, failures, asynchrony, progress
- What is a universal construction?
- Basic asynchronous read/write model
- Warm-up: a simple LL/SC-based universal construction
- Extensions: disjoint parallelism, abortable objects
- From memory operations to agreement objects
- Consensus object and consensus hierarchy
- Universal construction “1 among k ” and “ ℓ among k ”

Companion paper

Distributed Universal Constructions: a Guided Tour

by Michel Raynal

*Bulletin of the European Association
of Theoretical Computer Science (EATCS)*
121(1):64-96 (2017)

A citation

“*In sequential systems, computability is understood through the Church-Turing Thesis: anything that can be computed, can be computed by a Turing Machine.*”

In *distributed systems*, where computations require coordination among *multiple participants*, computability questions have a different flavor. Here, too, there are many problems which are not computable, but these *limits to computability reflect the difficulty of making decisions in the face of ambiguity, and have little to do with the inherent computational power of individual participants.*”

- Herlihy M., Rajsbaum S., and Raynal M., Power and limits of distributed computing shared memory models. *Theoretical Computer Science*, 509:3-24 (2013)

Computation model (base wait-free model)

- Process and failure model:

- ★ A set of n **asynchronous** processes p_1, \dots, p_n
- ★ “Asynchronous” means each process proceeds at its own speed, which can be arbitrary and remains always unknown to the other processes.
- ★ Up to $t < n - 1$ processes may **crash**
- ★ A process that crashes: **faulty**, otherwise: **non-faulty**

- Communication model:

- ★ The processes communicate with **atomic read/write registers** (memory locations)
- ★ “Atomicity” (or Linearizability) means that the read and write primitive operations on a register appear as if they have been executed one after the other

- Notation: $CA\mathcal{R}W_n[\emptyset]$

Linearizability (atomicity) and non-determinism

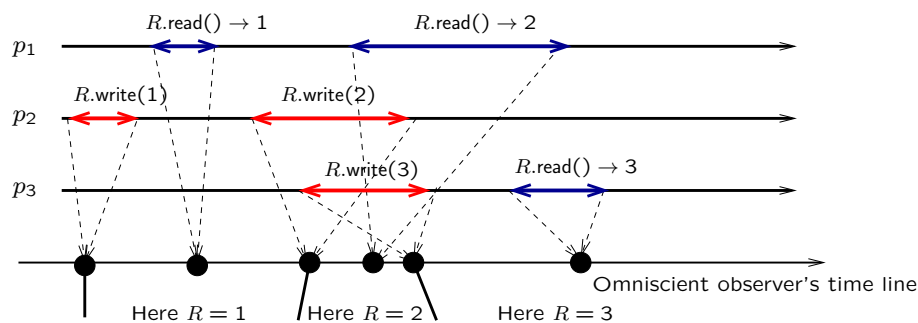

Possibly different linearizations,
but all respect physical order on operations

A remark on the message-passing model

- **Message-passing model:**

- ★ complete point-to-point network
- ★ no bound on transfer delays (but finite)
- ★ reliable (no loss, creation, duplication, alteration)

- In the presence of up to t failures:

- ★ **Crash:** the read/write model can be simulated on top the message-passing model only iff $t < n/2$

- Attiya H., Bar-Noy A. and Dolev D., Sharing memory robustly in message passing systems, *Journal of the ACM*, 42(1):121-132 (1995)

- ★ **Byzantine:** the read/write model can be simulated on top the message-passing model only iff $t < n/3$

- Imbs D., Rajsbaum S., Raynal M., and Stainer J., Reliable shared memory abstractions on top of asynchronous Byzantine message-passing systems, *Journal of Parallel and Distributed Computing*, 93-94:1-9 (2016)

Concurrent objects

- **Concurrent object**: object that can be accessed (possibly simultaneously) by several processes
- Here: defined by
 - * a **sequential specification**
 - * on **total operations**
- Remark: not all objects have a seq. specification
- Fundamental problem of shared memory distributed programming:
implement high level concurrent objects, where “high level” means that the object provides the processes with an abstraction level higher than the atomic hardware-provided instructions

On Progress conditions

- Failure-free model
 - * Deadlock-freedom
 - * Starvation-freedom
- Wait-free model
 - * Locks (mutex) cannot be used!
 - * three progress conditions
 - * Wait-freedom
 - * Non-blocking
 - * Obstruction-freedom

Wait-freedom

- Any operation (on the object that is built) issued by a process that does not crash terminates (whatever the behavior of the other processes)
- The strongest progress condition

- Herlihy M.P., Wait-free synchronization. *ACM Transactions on Programming Languages and Systems*, 13(1):124-149 (1991)

Non-blocking aka Lock-freedom

- At least one process can always progress (all its object operations terminate)
- Generalized: k -lock-freedom which states that at least k processes can always make progress
- n -lock-freedom = wait-freedom

- Herlihy M.P. and Wing J.M, Linearizability: a correctness condition for concurrent objects. *ACM Transactions on Programming Languages and Systems*, 12(3):463-492 (1990)

Obstruction-freedom

- A process that does not crash terminates its operation if all the other processes hold still long enough
- *k*-obstruction-freedom states that, if a set of at most *k* processes run alone for a sufficiently long period of time, they will terminate their operations
- Differently from wait-freedom and non-blocking, the definition of obstruction-freedom depends on concurrency pattern

- Herlihy M.P., Luchangco V., and Moir M., Obstruction-free synchronization: double-ended queues as an example. *Proc. 23th Int'l IEEE Conference on Distributed Computing Systems (ICDCS'03)*, IEEE Press, pp. 522-529 (2003)

Universal construction

- Let PC be a progress condition
- A **PC-compliant universal construction** is an algorithm that, given the sequential specification of an object *O* (or a sequential implementation of it), provides a concurrent implementation of *O* satisfying *PC* in the presence of up to $(n - 1)$ process crashes



What can be done in pure read/write systems

Let us consider $\mathcal{CARW}_n[\emptyset]$

- **OB-compliant** universal construction: **easy**
- **WF-compliant** universal construction: **impossible**
 - Fischer M.J., Lynch N.A., and Paterson M.S., Impossibility of distributed consensus with one faulty process. *Journal of the ACM*, 32(2):374-382 (1985)
 - Loui M. and Abu-Amara H., Memory requirements for agreement among unreliable asynchronous processes. *Advances in Computing Research*, 4:163-183, JAI Press (1987)
- to implement **WF-compliant universal constructions** $\mathcal{CARW}_n[\emptyset]$ must be enriched with hardware operations providing (strong enough) additional computational power
- in the following: WF-compliant universal constructions

Enriching the basic read-write model with LL/SC

- Notation $\mathcal{CARW}[\text{LL/SC}]$
- The **atomic operations LL and SC**
- Let *X* a memory location and p_i the invoking process
 - ★ ***X*.LL()** returns the current value of *X*
 - ★ ***X*.SC()** is a **conditional write**, returns a Boolean
 - let p_i be the process that issues $X.\text{SC}(v)$. This writes succeeds (the value *v* is written into *X* and true is returned) iff *X* has not been written by an other process since the last reading of *X* by p_i ($X.\text{LL}()$)
 - ★ Weak variants exist on some architectures such as Alpha AXP (ld_l/stl_c), IBM PowerPC (lwarx/stwcx)

The pair Load Linked/Store Conditional

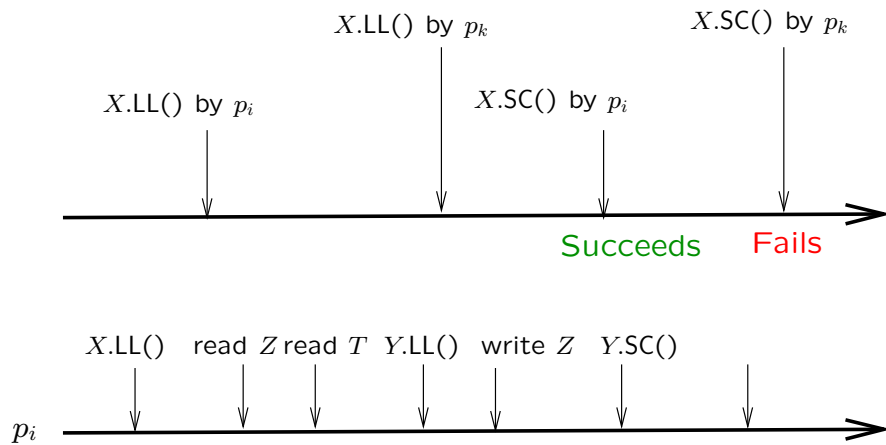

An algorithmic definition

Assume a boolean array $valid_X[1..n]$ init to $[false, \dots, false]$

operation $X.LL()$ issued by p_i is
 $valid_X[i] \leftarrow true; return(X).$

operation $X.SC(v)$ issued by p_i is
if $\neg valid_X[i]$ **then** $return(false)$
else $X \leftarrow v;$
 $\forall j : valid_X[j] \leftarrow false;$
 $return(true)$

end if.

LL/SC in action

Notion of a speculative execution

```

 $x_i \leftarrow X.LL();$  %  $x_i$  : local copy of  $X$  %
Statements (involving accesses to local memory
and possibly accesses to the shared memory)
computing a new value for  $X$ ;
% this is the speculative execution %
if  $X.SC(v)$  then statement associated with success
else statement associated with failure
end if.

```

A simple universal construction

- due to: Fatourou P. and Kallimanis N.D., Highly-efficient wait-free synchronization. *Theory of Computing Systems*, 55:475-520 (2014)
- Here we consider a simplified version with increasing sequence numbers
- Shared memory representation
 - * a non-atomic collect object *BOARD* of size n
 - * an array of n atomic memory locations *STATE*

The collect object

- Array $BOARD[1..n]$ with one entry per process
- provides each p_i with two operations: $update()$ and $collect()$
- $BOARD.update(v)$ by process p_i : assigns v to $BOARD[i]$
- $BOARD.collect()$: asynchronous scan of the array returning, for each entry j , the value read from $BOARD[j]$
- $collect()$ is not atomic (\Leftarrow asynchronous scan)
- $BOARD[i]$ contains a pair $\langle op, sn \rangle$ where op is the last operation on O issued by p_i and sn is its seq number

STATE: the representation of the object O

$STATE$ is a memory location made up of three fields

- $STATE.value$: current value of O
- $STATE.sn[1..n]$: array of seq numbers (init. $[0, \dots, 0]$)
 $STATE.sn[i] =$ seq number of p_i 's last invocation on O
- $STATE.res[1..n]$: array of result values (init. $[\perp, \dots, \perp]$)
 $STATE.res[i] =$ result of the last operation issued by p_i

Local variable sn_i at every process p_i (init 1)

The sequential specification of the object O

- Defined by a transition function $\delta()$
- inputs:
 - * s : the current state of O
 - * $op(in)$: invocation of the operation $op(in)$ on O
- $\delta(s, op(in))$ outputs a pair $\langle s', r \rangle$ such that
 - * s' is the state of O after the execution of $op(in)$ on s ,
 - * and r is the result of $op(in)$

Construction: operation invocation

```
when  $p_i$  invokes  $op(in)$  do
   $BOARD.update(\langle op(in), sn_i \rangle)$ ;
   $sn_i \leftarrow sn_i + 1$ ;
   $apply()$ ;
  let  $r = STATE.res[i]$ ; return( $r$ ).
```

Procedure `apply()` (1)

internal procedure `apply()` is

```

 $ls \leftarrow STATE.LL();$ 
 $pairs \leftarrow BOARD.collect();$ 
for  $\ell \in \{1, 2, \dots, n\}$  do
  if ( $pairs[\ell].sn = ls.sn[\ell] + 1$ ) then
     $\langle new\_state, r \rangle \leftarrow \delta(ls.value, pairs[\ell].op);$ 
     $ls.res[\ell] \leftarrow r; ls.sn[\ell] \leftarrow pairs[\ell].sn$ 
  end if
end for
 $STATE.SC(ls)$ 

```

Properties

- An operation cannot be executed more than once
- If a process does crash during its invocation, it terminates its operation (seq. asynchronous code)
- But is the result returned for the operation correct?

An execution

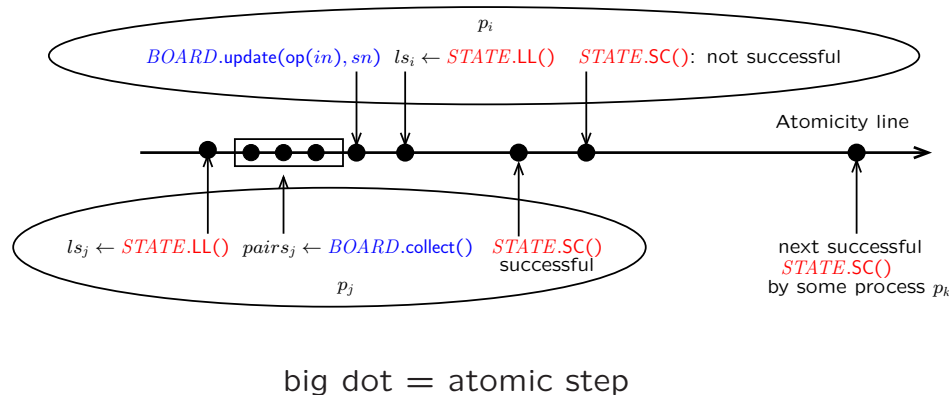

Final algorithm for `apply()`

internal procedure `apply()` is

repeat twice

```

 $ls \leftarrow STATE.LL();$ 
 $pairs \leftarrow BOARD.collect();$ 
for  $\ell \in \{1, 2, \dots, n\}$  do
  if ( $pairs[\ell].sn = ls.sn[\ell] + 1$ ) then
     $\langle new\_state, r \rangle \leftarrow \delta(ls.value, pairs[\ell].op);$ 
     $ls.res[\ell] \leftarrow r; ls.sn[\ell] \leftarrow pairs[\ell].sn$ 
  end if
end for
 $STATE.SC(ls)$ 
end repeat twice.

```

Cost: $\leq 2n$ (seq.) shared memory accesses

Linearization points of the operations

- Let $SC[1], SC[2], \dots, SC[x], \dots$ be the sequence of the successful invocations of $STATE.SC()$
- As $STATE.SC()$ is atomic, this sequence is well-defined
- Starting from $SC[1]$, each $SC[x]$ applies at least one operation on the object O
- The operations applied to O by each $SC[x]$ are totally ordered
- Let $seq[x]$ be the corresponding sequence
- The sequence of operations applied to O is then $seq[1], seq[2], \dots, seq[x]$, etc.

Exercise: build an atomic collect object

- Consider an atomic object X with two operations
 - ★ $X.add(v)$ adds v to X
 - ★ $X.read()$ returns the value of X
- D = value domain of the entries of the collect object
- d = number of bits needed to represent a value of D
- X = atomic register of nd bits (n chunks of d bits)

Internal representation of X with nd bits

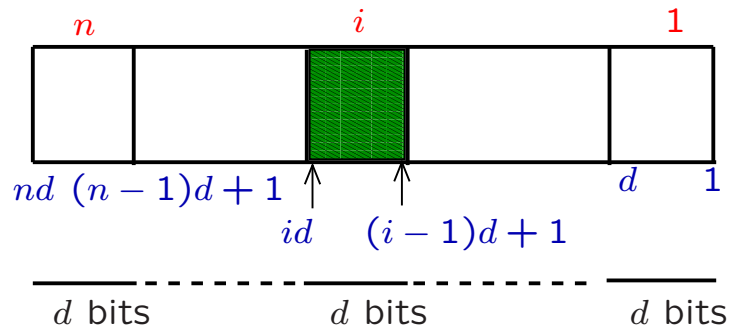

The operations of the atomic collect objects

v' = previous value written by p_i , init 0

operation $update(v)$ by p_i is

$\langle b_d, \dots, b_1 \rangle \leftarrow$ binary encoding of $(v - v')$;
 $val \leftarrow \langle 0, \dots, 0, b_d, \dots, b_1, 0, \dots, 0 \rangle$
 with $\langle b_d, \dots, b_1 \rangle$ in position $[id \dots (i-1)d + 1]$;
 $X.add(val)$; $v' \leftarrow val$;
 return.

operation $collect()$ is

$v \leftarrow X.read()$;
 decompose v according to the n -chunk encoding;
 return (corresponding array $r[1..n]$).

Exercise: replace $add()$ by $xor()$

The case of large objects

A **large object** is an object whose internal state cannot be copied in one atomic step (machine instruction)

- A large object is **fragmented into blocks**
- Pointers linking blocks: speculative execution with pointers manipulated with LL/SC

- Herlihy M.P., A methodology for implementing highly concurrent data objects. *ACM Trans. on Programming Languages and Systems*, 15(5):745-770 (1993)

- Long array fragmented into blocks: implemented with LargeLL and LargeSC operations (built from LL/SC-based algorithm)

- Anderson J. and Moir M., Universal constructions for large objects. *IEEE Transactions on Parallel and Distributed Systems*, 10(12):1317-1332 (1999)

Extension 1: disjoint-access parallelism (1)

- A universal construction is **disjoint-access parallel** if two processes that access distinct parts of an object O do not access common base objects or common memory location which constitute O 's internal representation
- As an example, let us consider a queue Q . When $|Q| \geq 3$, a disjoint-access parallelism implementation allows a process executing `enqueue(v)` and a process executing `dequeue()` to progress without interfering
- **Is it possible to design a disjoint-access parallelism WF-compliant universal construction?**

- Ellen F., Fatourou P., Kosmas E., Milani A., and Travers C., Universal constructions that ensure disjoint-access parallelism and wait-freedom. *Distributed Computing*, 29:251-277 (2016)

Example

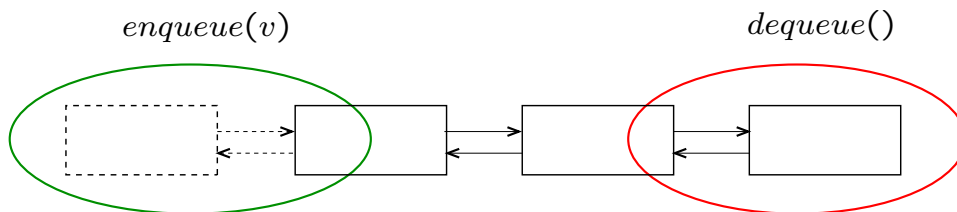

Extension 1: disjoint-access parallelism (2)

- General impossibility result: **Disjoint-access parallelism and wait-freedom are mutually exclusive when designing a universal construction**
- Specific possibility result: Possible for the object class containing all the objects O for which, in any sequential execution, each operation accesses a bounded number of base objects used to represent O . This class includes bounded trees, stacks and queues whose internal representations are list-based

Extension 2: abortable objects, definition

An **abortable object** is defined by a sequential specification and such that

- When executed in a concurrency-free context, an operation takes effect, i.e., modifies the state of the object and returns a result as defined by its sequential specification
- When executed in a concurrency context, an operation either takes effect and returns a result as defined by its sequential specification, or returns the default value \perp (abort)

An operation returning \perp has no effect on the state of the object

The operations of an abortable object always terminate

WF-compliant universal const. for Abort. Objects

- Successful speculative execution returns a value
- Unsuccessful speculative execution returns \perp (occurs only in a concurrency pattern)

```
when  $p_i$  invokes  $op(in)$  do
   $ls \leftarrow STATE.LL()$ ;
   $\langle new\_state, r \rangle \leftarrow \delta(ls, op(in))$ ;
   $done \leftarrow STATE.SC(new\_state)$ ;
  if ( $done$ ) then return( $r$ ) else return( $\perp$ ) end if.
```

k -abortable objects

- An operation is allowed to abort only if it is concurrent with operations issued by k distinct processes and none of them returns \perp (abort)
- This means that the k operations that entail the abort of another operation must succeed
- n -abortability is \perp -free wait-freedom
- A (non-trivial) WF-compliant universal construction for k -abortable objects exists in $\mathcal{CARW}_n[LL/SC]$

- Ben-David N., Cheng Chan D.Y., Hadzilacos V. and Toueg S., k -Abortable objects: progress under high contention. *Proc. 30th Int'l Symposium on Distributed Computing (DISC'16)*, Springer LNCS 9888, pp. 298-312 (2016)

Universal constructions

From operations on memory locations
to agreement objects

Hardware-provided uniform operations

- The previous universal constructions are based on hardware-provided atomic operations such as LL/SC
- These **hardware-provided atomic operations are uniform** the sense they can be applied to any memory location
- Memory locations are not “objects” in the classical sense (e.g. a push() operation on a stack is meaningless on a set).

A few important questions

- Can we design WF-compliant universal constructions with hardware atomic operations such as Test&Set or Fetch&Add?
- Are all hardware atomic operations “equal” wrt WF-compliant universal constructions?
- Is it possible to generalize the concept of a universal construction to the coordinated construction of several objects with different progress conditions?

A fundamental object: **Consensus**

- A single operation denoted **propose()** that
 - ★ a process can invoke only once
 - ★ has an input parameter (proposed value) and a result (decided value)
- Consensus is defined by the following three properties:
 - ★ **Validity**. A decided value is a proposed value
 - ★ **Agreement**.
No two processes decide different values
 - ★ **Termination**.
If a correct process invokes **propose()**, it decides

A simple **consensus-based WF-compliant UC (1)**

- Inspired from the state machine replication paradigm
- Each process p_i manages
 - ★ a local copy of the object O : $state_i$
 - ★ an array $sn_i[1..n]$
 $sn_i[j]$ = sequence number of the last operation on O issued by p_j , locally applied to $state_i$

A simple consensus-based WF-compliant UC (2)

Shared memory

- An array $BOARD[1..n]$ of SWMR atomic registers
 - * $BOARD[j] = \langle BOARD[j].op, BOARD[j].sn \rangle$
 - * $BOARD[j].op$ = last operation issued by p_j
 - * $BOARD[j].sn$ = its sequence number
 - * $BOARD[j]$: initialized to $\langle \perp, 0 \rangle$
 - * An unbounded array $CONS[1..]$ of consensus objects

- Raynal M., Concurrent Programming: Algorithms, Principles and Foundations. Springer, 515 pages (2013)

Structural view of the Universal construction

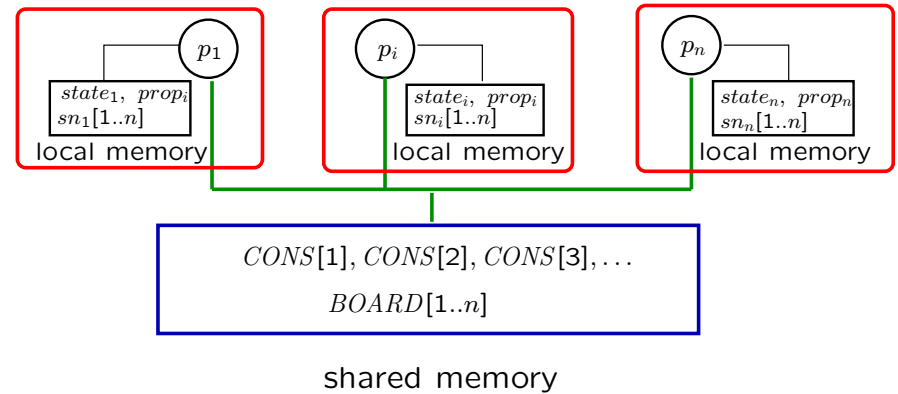

A simple consensus-based UC

```
when  $p_i$  invokes  $op(in)$  do
   $done_i \leftarrow false$ ;
   $BOARD[i] \leftarrow \langle op(in), sn_i[i] + 1 \rangle$ ;
  wait ( $done_i$ );
  return( $res_i$ ).
```

Underlying local task T (1)

```
while (true) do
   $prop_i \leftarrow \epsilon$ ; % empty list %
  for  $j \in \{1, \dots, n\}$  do
    if ( $BOARD[j].sn > sn_i[j]$ ) then
      append ( $BOARD[j].op, j$ ) to  $prop_i$ 
    end if
  end for;
  if ( $prop_i \neq \epsilon$ ) then see NEXT SLIDE end if
end while.
```

Underlying local task T (2)

```

 $k_i \leftarrow k_i + 1;$ 
 $list_i \leftarrow CONS[k_i].propose(prop_i);$ 
for  $r = 1$  to  $|list_i|$  do
   $\langle state_i, res_i \rangle \leftarrow \delta(state_i, list_i[r].op);$ 
  let  $j = list_i[r].proc;$   $sn_i[j] \leftarrow sn_i[j] + 1;$ 
  if  $(i = j)$  then  $done_i \leftarrow true$  end if
end for.

```

Simple sequence of consensus instances to agree on the same sequence of operations applied to the object O

Bounded WF vs Unbounded WF

- **Bounded-wait-freedom:**
the number of steps (accesses to the shared memory) executed before an operation terminates is bounded
- **Unbounded-wait-freedom:**
the number of steps (accesses to the shared memory) executed before an operation terminates is finite (not bounded)
- This construction ensures that the operations issued by the processes are wait-free, but does not guarantee that they are bounded-wait-free (processes have to catch up)
- There are bounded WF universal constructions

A bounded WF universal construction

The object representation is in the shared memory

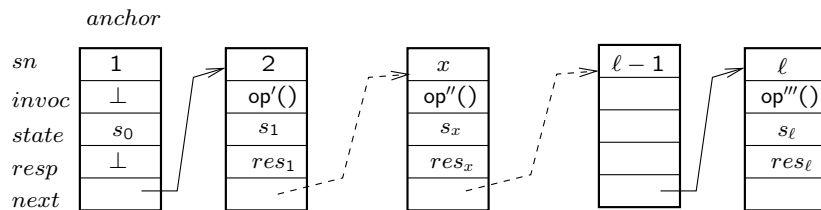

- A list of objects modifications + a helping mechanism
- Next pointers: **consensus objects allowing the processes to agree on the sequence of operations** applied to the object

- Herlihy M.P., Wait-free synchronization. *ACM Transactions on Programming Languages and Systems*, 13(1):124-149 (1991)

Consensus number

- Let us consider an object of type T (defined by a sequential specification)
- The **consensus number** of an object of type T is the greatest integer n such that it is possible to implement a consensus object in a system of n processes, with any number of atomic read/write registers and objects of type T
- The consensus number is $+\infty$ if there is no largest n

The consensus hierarchy

- The consensus number of **read/write registers** is **1**

It follows that all objects that can be built from read/write registers only (i.e., in $\mathcal{CARW}_n[\emptyset]$ without enrichment with additional operations) have consensus number 1

- The consensus number of hardware operations such as **Test&Set**, **Fetch&Add**, **Swap**, and a few others, is **2**
- Let a **k -window read/write register** be a register that stores only the sequence of the last k values which have been written, and whose read operation returns this sequence of at most k values. The consensus number of a k -window is **k**
- Finally, the consensus number of **Compare&Swap**, **LL/SC**, and a few others, is **$+\infty$**

Universality of consensus

- Consensus objects are universal in the sense they allow to WF-implement any object defined by a sequential specification in $\mathcal{CARW}_n[\emptyset]$
- Any hardware-provided operation h_{op} whose consensus number is n is universal in $\mathcal{CARW}_n[h_{op}]$

This means that any object defined by a sequential specification can WF-implemented in $\mathcal{CARW}_n[h_{op}]$

Universal constructions

Consensus from several operations on memory locations

The problem

- The previous hierarchy considers consensus built from read/write registers and objects of a given type T only
- **What can be done with when several hardware operations which access the same memory locations are given?**

- Ellen F., Gelashvili G., Shavit N. and Zhu L., A complexity-based hierarchy for multiprocessor synchronization (Extended abstract). *Proc. 35th ACM Symposium on Principles of Distributed Computing (PODC'16)*, ACM Press, pp. 289-298 (2016)

Illustration

- System model $\mathcal{CARW}_n[\text{Test\&Set}, \text{Fetch\&Add2}]$
 - ★ **Test&Set** returns the value in the memory location, and sets it to 1 if it contained 0
 - ★ **Fetch&Add2** returns the value in the memory location and increases it by 2 (preserves parity: invariant)
- Test&Set and Fetch&Add2 have consensus number 2
- Which power has $\mathcal{CARW}_n[\text{Test\&Set}, \text{Fetch\&Add2}]$?

Binary consensus object for any n

A single memory location X , initialized to 0

operation propose(v) **is**

```
if ( $v = 0$ )
  then  $x \leftarrow X.\text{fetch\&add2}()$ ;
       if ( $x$  is odd) then return(1) else return(0) end if
else  $x \leftarrow X.\text{test\&set}()$ ;
     if ( $x$  is odd)  $\vee$  ( $x = 0$ )
       then return(1) else return(0)
     end if
end if.
```

- Decision is sealed by the first atomic operation executed
- If the first operation executed is
 - ★ fetch&add2(): X becomes and remains even forever (decision 0)
 - ★ test&set(): X becomes and remains odd forever (decision 1)

Power number of an object type T

- Definition:
The **power number** of an object type T ($\text{PN}(T)$) is the largest integer k such that it is possible to implement a **k -obstruction-free consensus object for any number of processes**, using any number of atomic read/write registers, and any number of objects of type T (the registers and the objects of type T being wait-free)
If there is no such largest k , $\text{PN}(T) = +\infty$
- We have $\text{CN}(T) = \text{PN}(T)$
- Establish a **strong relation linking wait-freedom and k -obstruction-freedom** (progress conditions)

- Taubenfeld G., On the computational power of shared objects. *Proc. 13th Int'l Conference on Principles of Distributed Systems (OPODIS'09)*, Springer LNCS 5923, pp. 270-284 (2009)

Universal constructions

“1 among k ” and “ ℓ among k ”

Aim

- Consider k objects (state machines, seq. specification)
- Design a WF-compliant universal construction such that
 - ★ at least one object progresses forever
 - ★ at least ℓ objects progress forever

- Gafni E. and Guerraoui R., Generalizing universality. *Proc. 22nd Int'l Conference on Concurrency Theory (CONCUR'11)*, Springer LNCS 6901, pp. 17-27 (2011)

- Raynal M., Stainer J., and Taubenfeld G., Distributed universality. *Algorithmica*, 76(2):502-535 (2016)

Another agreement object: k -set agreement

k -SA is consensus where up to k values can be decided

- **Validity.** A decided value is a proposed value
- **Agreement.**
At most k different values are decided
- **Termination.**
If a correct process invokes propose(), it decides a value

- Chaudhuri S., More choices allow more faults: set consensus problems in totally asynchronous systems. *Information and Computation*, 105(1):132-158 (1993)

Yet another agreement object: k -simultaneous cons.

propose() takes as input parameter a vector of size k , whose each entry contains a value, and returns a pair $\langle x, v \rangle$

- **Validity.**
A decided pair $\langle x, v \rangle$ is such that v was proposed by a process in the entry x of its input vector parameter
- **Agreement.**
If $\langle x, v \rangle$ and $\langle y, w \rangle$ decided, we have $(x = y) \Rightarrow (v = w)$
- **Termination.**
If a correct process invokes propose(), it decides

- Afek Y., Gafni E., Rajsbaum S., Raynal M., and Travers C., The k -simultaneous consensus problem. *Distributed Computing*, 22(3):185-195 (2010)

k -set agreement vs k -SC

- In read/write systems: They are equivalent
- In message-passing systems:
 k -SC is strictly stronger than k -set agreement

- Afek Y., Gafni E., Rajsbaum S., Raynal M., and Travers C., The k -simultaneous consensus problem. *Distributed Computing*, 22(3):185-195 (2010)

- Bouzid Z. and Travers C., Simultaneous consensus is harder than set agreement in message-passing. *Proc. ICDCS'13*, IEEE Press, pp. 611-620 (2013)

- Raynal M. and Stainer J., Simultaneous consensus vs set agreement: a message-passing-sensitive hierarchy of agreement problems. *Proc. SIROCCO'13*, Springer LNCS 8179, pp. 298-309 (2013)

Guerraoui-Gafni's question

- Their question: **Is 1 a special value?** (wrt $k \in [2..n]$)
- **k -set agreement:**
 - ★ Allows up to k different values to be decided
 - ★ 1-set agreement is consensus
- What they do:
 - ★ They consider the implementation of k objects (each defined by a seq. specification) instead of only one, and “replace” consensus by (k -simultaneous consensus (= k -set agreement) objects
 - ★ They provide a non-blocking universal construction in which at least one object progresses forever

Underlying basic object: adopt-commit (1)

- One-shot object
- A single operation denoted **propose()**, which
 - ★ takes a value v as input parameter
 - ★ and returns a pair $\langle tag, v' \rangle$

Gafni E., Round-by-round fault detectors: unifying synchrony and asynchrony. *Proc. 17th ACM Symposium on Principles of Distributed Computing (PODC)*, ACM Press, pp. 143-152 (1998)

Underlying basic object: adopt-commit (2)

- **Validity:**
 - ★ **Result domain:** Any returned pair $\langle tag, v \rangle$ is such that (a) v has been proposed by a process and (b) $tag \in \{commit, adopt\}$
 - ★ **No-conflicting values:** If a process p_i invokes $propose(v)$ and returns before any other process p_j has invoked $propose(v')$ with $v' \neq v$, then **only the pair $\langle commit, v \rangle$ can be returned**
- **Agreement:** If a process returns $\langle commit, v \rangle$, **only the pairs $\langle commit, v \rangle$ or $\langle adopt, v \rangle$ can be returned**

- **Termination:**

The invocation of $propose()$ by a correct process always terminates

Can be implemented in $CARW_n[\emptyset]$

The heart of GG11 universal construction

- $oper_i[m]$ = next op on object $m \in [1..k]$ by p_i
- One adopt-commit per round and object $m \in [1..k]$
 - (1) $\langle obj, op \rangle \leftarrow KSC[r_i].propose(oper_i[1..k]);$
 - (2) $(tag_i[obj], ac_op_i[obj]) \leftarrow AC[r_i][obj].propose(op);$
 - (3) **for each** $m \in \{1, \dots, k\} \setminus \{obj\}$ **do**
 $(tag_i[m], ac_op_i[m]) \leftarrow AC[r_i][m].propose(oper_i[m])$
end for

Why it works

At least one object operation is committed at every round

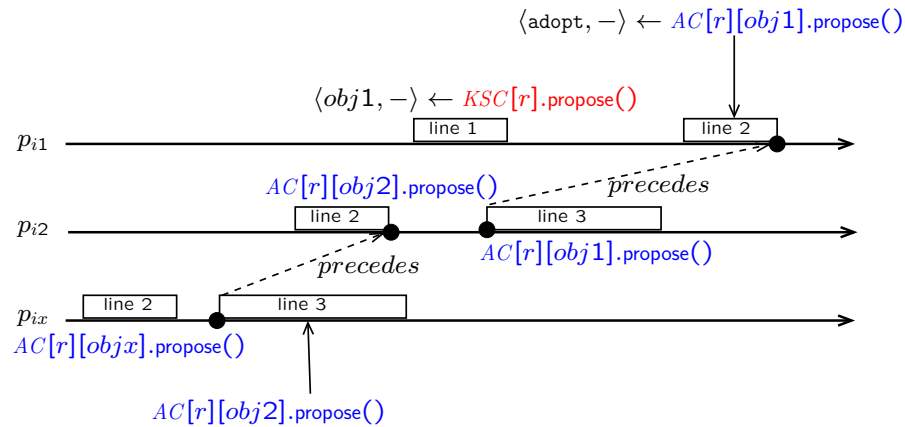

Summarizing GG11 Universal construction

- At least one process progresses forever: non-blocking
- At least one object progresses forever
- Hence, k -set agreement allow a coordinated NB-compliant universal construction of k objects (state machines), such that at least one object progresses forever

Beyond GG11 Universal construction!

- Design a **coordinated WF-compliant universal construction** of k objects (state machines), such that **at least $\ell \in [1..k]$ objects progress forever**

- Raynal M., Stainer J., and Taubenfeld G., Distributed universality. *Algorithmica*, 76(2):502-535 (2016)

RTS16 universal construction at a glance

- Introduces **(k, ℓ) -consensus objects** (k, ℓ constant)
- Considering k objects, it introduces a **(k, ℓ) -universal construction**
 - * in which ℓ ($1 \leq \ell \leq k$) **objects progress forever**
 - * in which the progress condition is **wait-freedom**
 - * that is **contention-aware** (only read/write registers are used in the absence of contention)
 - * that is generous wrt to the obstruction-freedom progress condition
- Shows that (k, ℓ) -consensus objects are **necessary and sufficient** for such a (k, ℓ) -universal construction

Remarks

- Contention awareness:
Cost(Compare&Swap) $\simeq 1000 \times$ Cost (read/write)
- Generosity: “dual” of indulgence

(k, ℓ) -simultaneous consensus (1)

- One-shot object
- A single operation denoted **propose()**, which
 - ★ takes a vector of size k as input parameter,
 - ★ and returns ℓ pairs $\langle x_1, v_1 \rangle, \dots, \langle x_\ell, v_\ell \rangle$
(where all x_j are different)

Underlying basic objects: (k, ℓ) -SC (2)

- **Validity**: A pair (x, v) returned by a process v has been proposed by a process in the x -th entry of its input vector
- **Agreement**: If a process returns $\langle x, v \rangle$ and another process returns $\langle y, v' \rangle$, then $(x = y) \Rightarrow (v = v')$
- **Termination**: An invocation of **propose()** by a correct process always terminates

The (k, ℓ) -universal construction (1)

- First a non-blocking $(k, 1)$ -universal construction is built
 - ★ It relies on copies of the views (histories) of each object by each process
 - ★ The consistency of these views is ensured thanks to $(k, 1)$ -simultaneous consensus objects
 - ★ Each view is a full object history (seq. of operations)
 - ★ This facilitates the statement and the proof universal construction
 - ★ The full objects history can be eliminated, and replaced by registers containing the state of each object

The (k, ℓ) -universal construction (2)

- Then, one step after the other, the algorithm is enriched
 - ★ to satisfy contention-awareness
 - ★ to ensure wait-freedom of each object operation
- Finally the $(k, 1)$ -simultaneous consensus objects are replaced by (k, ℓ) -simultaneous consensus objects to obtain a wait-free, contention aware, (k, ℓ) -universal construction

Conclusion

Remarks

- When $k = \ell = 1$, the universal construction obtained is the first contention-aware $(1, 1)$ -universal construction
- More generally, when $\ell = 1$, the resulting construction is the first contention-aware $(k, 1)$ -universal construction

-
- Quest for **distributed universal constructions is at the heart** of distributed computability
 - Understand distributed computability is mainly concerned by **mastering uncertainty (non-determinism)** created by the environment (mainly asynchrony, failures, and concurrency)
 - This quest is far from being finished...
 - Still **remain to have a deeper understanding of the relations between shared memory systems, message-passing communication abstractions, and agreement objects**